

## DRAIN SEALS

### PRODUCT INFORMATION



#### DESCRIPTION:

Platinum mechanical seals are expertly designed to provide a reliable, watertight connection between roof drain stems and existing plumbing drains while being versatile enough to fit different drain configurations, ensuring a dependable and long-lasting solution to prevent leaks and maintain effective drainage. Constructed from premium nylon and EPDM rubber, these seals offer exceptional durability and resistance to environmental conditions. Their strength is further reinforced by stainless steel screws, ensuring high performance across various applications. Available in sizes ranging from 3 to 6 inches,

#### APPLICATION:

To activate the seal, use the PLATINUM screwdriver to tighten the internal stainless steel screws. This action compresses the thermoplastic seal, causing it to expand and create a secure fit against the wall of the existing pipe. As a result, water leakage at the connection is prevented, effectively stopping any water backup and mitigating damage. The flexible rubber expands and locks in place, halting vertical movement and ensuring a reliable seal.

#### FEATURES & BENEFITS:

- Easy to install
- Provides a watertight seal to prevent damage from water backup
- Compatible with aluminum, stainless steel, & copper retrofit drains

#### STANDARDS & APPROVALS:

ANSI/SPRI RD-1 is a national performance standard for retrofit roof drains. Although most retrofit drains are not tested to this standard, PLATINUM Insert Drains surpass it. The standard requires that the seal withstand a 10-foot column of water for 24 hours without any leakage.



#### PHYSICAL DATA

SEAL SIZE (in)	SKU	SMALL END O.D.(in)	LARG END O.D.(in)	LARGE END MIN. EXPANSION(in)
3	P-3S-12	2.62±0.001"	2.87±0.001"	>3.34"
4	P-4S-12	3.50±0.002"	3.74±0.001"	>4.13"
5	P-5S-12	4.55±0.002"	4.81±0.002"	>5.39"
6	P-6S-12	5.44±0.002"	5.76±0.002"	>6.22"

## DRAIN SEALS

### INSTALLATION INSTRUCTIONS

- 1** Clean any debris from drain and pipe prior to seal installation to ensure proper seal installation and expansion.
- 2** Before installing, ensure you select the correct seal size. Once the appropriate size is chosen, insert the seal into the drain's pipe stem. Evenly tighten the stainless steel screws to expand the top half of the seal, securing it firmly to the drain stem. Use the Platinum screwdriver with 24" extension to tighten the screws through the top of the drain until the seal expands fully and locks securely in place.
- 3** Place the entire assembly into the roof drain pipe until drain deck lies flush on roof membrane. Install the drain and tighten all screws evenly, ensuring not to over-tighten to achieve proper and uniform seal expansion. Continue to tighten the stainless steel screws until they are securely fixed in place, but avoid over-tightening. Once completed, the drain will be fully leakage-proof.
- 4** Tighten the seal screws in a sequential manner to ensure uniform compression of the seal's compressing ring (the lowest part of the seal). Tighten each screw a few turns at a time, working one by one. Repeat this process until the screws are hand-tight and no vertical movement of the drain is observed. 3-inch and 4-inch seals each have three screws, while 5-inch and 6-inch seals have four screws. Follow the tightening order indicated on fig.1 below. The installation is complete when the drain body remains stable under pressure with no vertical movement. Avoid over-tightening the screws.

**NOTE:** If the following procedures and tightening sequences in the steps provided are not met, possible improper seal installation may result.

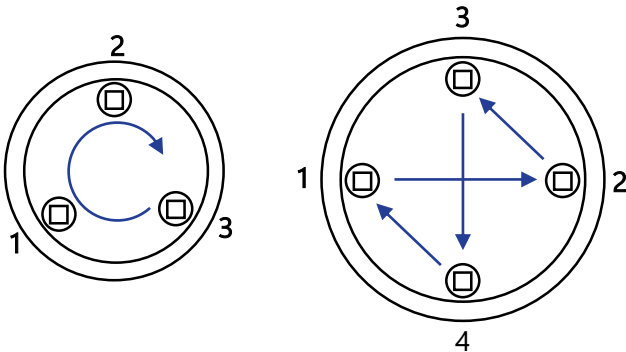

### SHORTENING A RETROFIT DRAIN STEM

In certain situations, you may need to shorten the drain stem if the existing vertical distance is insufficient to fit the retrofit drain stem as it comes.

#### STEP 1

Ensure there is at least 4 inches of clear vertical space in the existing pipe to accommodate the drain. Cut the drain stem to the required length, making sure to leave at least 2.5 inches for the seal. Insert the Seal into the cut drain stem.

#### STEP 2

Place the seal into the cut drain stem and tighten the seal screws. Once the drain and seal are assembled, insert the unit into the existing water leader and proceed with steps 2 through 4.

### PLATINUM DRAIN SEAL SCREW DRIVER

The PLATINUM 24" Screwdriver is an accessory specifically engineered for installing Platinum seals. It features an extra-long extension with a square socket tip (#2 Robertson) designed for tightening the recess head screws on the seals. The 20" shaft provides extended reach, making it easier to tighten the seal connection screws effectively.

#### WHAT'S INCLUDED:

E6.3 silicon alloy steel square bit(#2 Robertson)



10 teeth bit ratchet T-handle with 36° working angle bit holder with maximum torque of 4.8nm



20" extension bit holder  
1/4" stainless steel with quick  
disconnect & locking bit system

There is no equal to **PLATINUM!**

Please note that PLATINUM products may be periodically updated & are subject to change without prior notice.  
For additional information, contact PLATINUM ROOFING PRODUCTS at 1-800-538-7767 or [info@platinumroofingproducts.com](mailto:info@platinumroofingproducts.com)